

2/2

VALVES FOR HYDRAULIC OIL AND NEUTRAL LIQUIDS (UP TO 100 BAR)
PILOT OPERATED

BRASS

PIPE MOUNTING

NORMALLY CLOSED

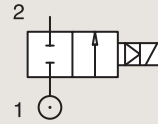

Port size	Orifice Ø	Flow factors			Operating Pressure Differential Max(MOPD)			Fluid Temp.		Seat Seal	Valve Ref.	Housing Ref.	Coil Ref.	Power		Coil Group	Dwg. No.					
														Min	AC bar			DC bar	Min	Max	AC W	DC W
BSP	mm	Kv l/min	KV m³/h	Qn l/min	bar	AC bar	DC bar	°C	°C													
1/4"	8	36	2.16	1600	0.3	40	25	-10	100	NBR	E321H11 ¹²	2995	481865	8	9	2.0	3523					
	8	36	2.16	1600	0.3	40	30	-10	100	NBR	E321H11 ¹²	4270	481000	8	8	2.0	3523					
	8	36	2.16	1600	0.3	40	40	-10	100	NBR	E321H11 ¹²	4270	486265	14	14	2.0	3523					
	8	36	2.16	-	0.3	40	25	-10	100	FKM	E321H21 ¹²	2995	481865	8	9	2.0	3523					
	8	36	2.16	-	0.3	40	30	-10	120	FKM	E321H21 ¹²	4270	481000	8	8	2.0	3523					
	8	36	2.16	-	0.3	40	40	-10	140	FKM	E321H21 ¹²	4270	486265	14	14	2.0	3523					
3/8"	11	50	3	2800	0.3	40	25	-10	100	NBR	E321H13 ¹²	2995	481865	8	9	2.0	3521					
	11	50	3	2800	0.3	40	30	-10	100	NBR	E321H13 ¹²	4270	481000	8	8	2.0	3521					
	11	50	3	2800	0.3	40	40	-10	100	NBR	E321H13 ¹²	4270	486265	14	14	2.0	3521					
	11	50	3	-	0.3	40	25	-10	100	FKM	E321H23 ¹²	2995	481865	8	9	2.0	3521					
	11	50	3	-	0.3	40	30	-10	120	FKM	E321H23 ¹²	4270	481000	8	8	2.0	3521					
	11	50	3	-	0.3	40	40	-10	140	FKM	E321H23 ¹²	4270	486265	14	14	2.0	3521					
	11	36	2.16	-	0.2	20	3	-10	100	Ruby	E321K63	2995	483510	9	-	2.0	3429					
	11	36	2.16	-	0.2	30	4	-10	140	Ruby	E321K63	4270	488553	9	-	2.0	3429					
11	36	2.16	-	0.2	4	4	-10	75	Ruby	E321K63	-	492190	11	9	2.0	3429						

Notes:

1. Minimum pressure differential = 0.3 bar for opening and 0 bar for closing
2. Pilot seat disc in synthetic Ruby



For this page	Port size	Orifice (mm)	Kv (l/min)	MOPD (bar)	Fluid Temp (°C)
From	1/4"	8	36	3	-10
To	3/8"	11	50	40	140

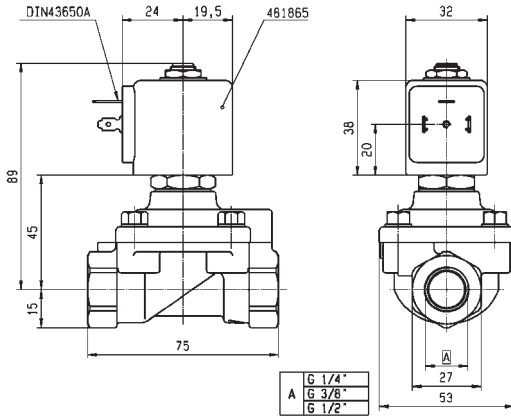

Drawing 3523

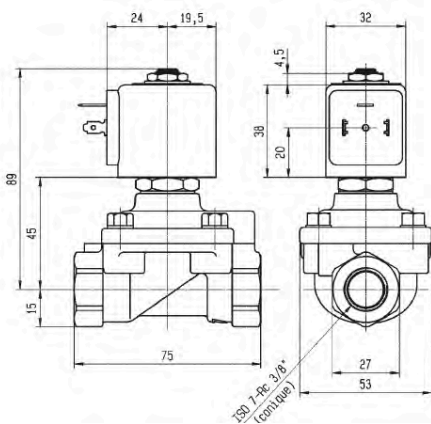

Drawing 3521

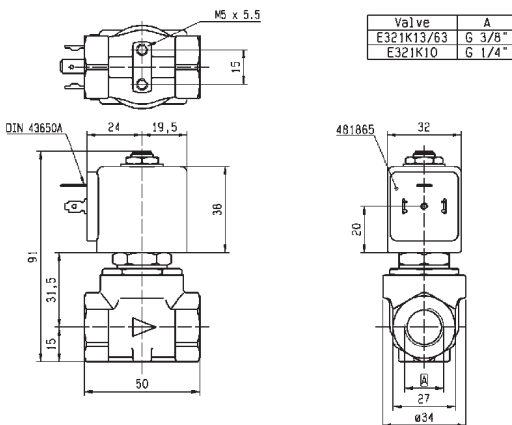

Drawing 3429